

3-PHASE CAPSTAN MOTOR DRIVER

The KA8329B is a monolithic integrated circuit, and suitable for 3-phase capstan motor driver of VCR system.

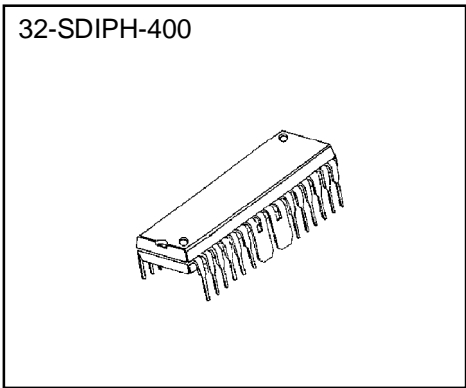

FEATURES

- 3-phase, full-wave, linear BLDC motor driver with 3 hall sensors
- Built-in TSD(Thermal Shutdown) circuit
- Built-in torque ripple control circuit
- Built-in output current limiter
- Motor speed control
- High output current
- Built-in FG amplifier with sinusoidal waveforms
- Built-in hall amplifier
- Built-in CW and CCW circuit

ORDERING INFORMATION

Device	Package	Operating Temperature
KA8329B	32-SDIPH-400	- 20 ~ + 75 °C

BLOCK DIAGRAM

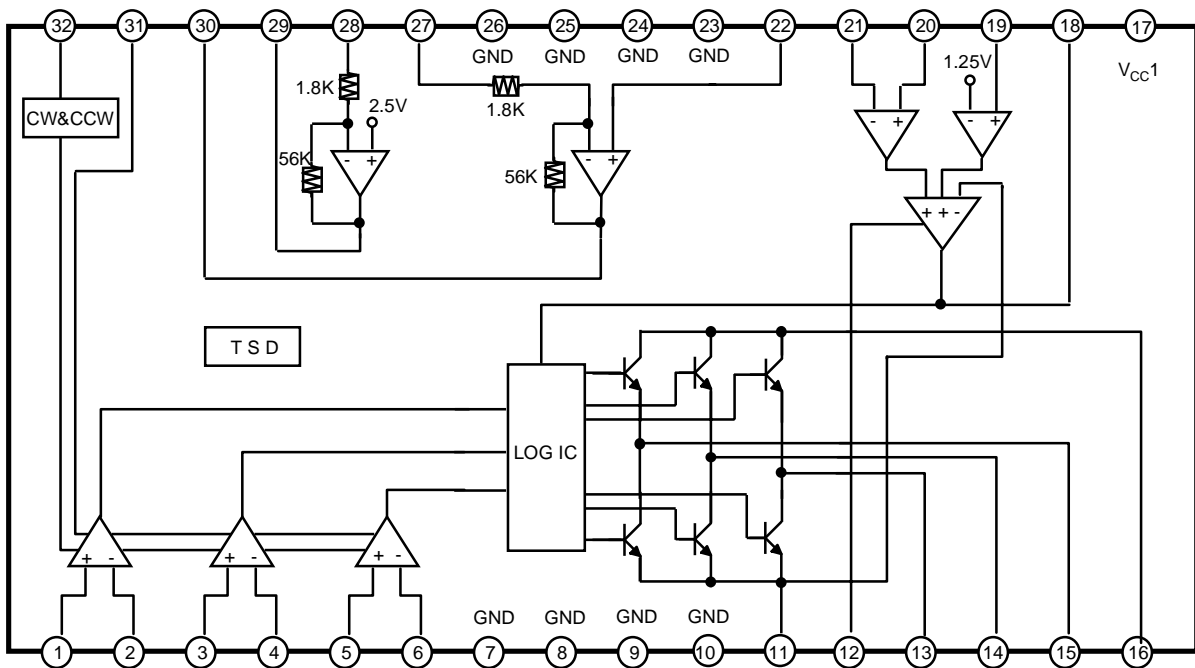

PIN CONFIGURATION

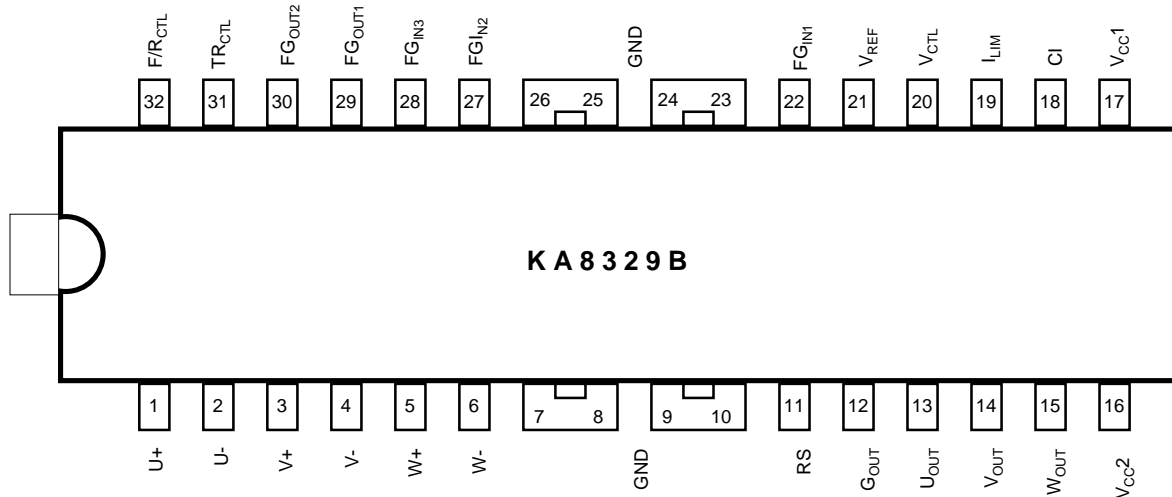

PIN DESCRIPTION

Pin No.	Symbol	I/O	Description	Pin No.	Symbol	I/O	Description
1	U +	I	U + Hall Signal Input	17	V _{CC1}	-	Supply voltage(signal)
2	U -	I	U - Hall Signal Input	18	CI	-	Phase stabilization
3	V +	I	V + Hall Signal Input	19	I _{LIM}	I	Current limitation
4	V -	I	V - Hall Signal Input	20	V _{CTL}	I	Voltage control
5	W +	I	W + Hall Signal Input	21	V _{REF}	I	Voltage control reference
6	W -	I	W - Hall Signal Input	22	FG _{IN1}	I	FG AMP1 input1
7	GND	-	Ground(Signal)	23	GND	-	Ground(signal)
8	GND	-	Ground(Signal)	24	GND	-	Ground(signal)
9	GND	-	Ground(Signal)	25	GND	-	Ground(signal)
10	GND	-	Ground(Signal)	26	GND	-	Ground(signal)
11	RS	O	Output Current Detection	27	FG _{IN2}	I	FG AMP1 input2
12	G _{OUT}	-	Ground(Power)	28	FG _{IN3}	I	FG AMP2 input1
13	U _{OUT}	O	U - Phase Output	29	FG _{OUT1}	O	FG AMP2 output
14	V _{OUT}	O	V - Phase Output	30	FG _{OUT2}	O	FG AMP1 output
15	W _{OUT}	O	W - Phase Output	31	TR _{CTL}	I	Torque ripple control
16	V _{CC2}	-	Supply Voltage(Power)	32	F/R _{CTL}	I	Forward & reverse control

ABSOLUTE MAXIMUM RATING (Ta = 25°C)

Characteristics	Symbol	Value	Unit	Remark
Supply Voltage(Signal)	V _{CC1}	7	V	
Supply Voltage(Power)	V _{CC2}	28	V	
Output Current	I _{OUT}	1.5	A/phase	
Power Dissipation	P _D	2.4	W	No Heat Sink
Thermal Resistance	R _T	60.2	mw/°C	No Heat Sink
Junction Temperature	T _J	150	°C	
Operating Temperature	T _{OPR}	- 20 ~ + 75	°C	
Storage Temperature	T _{STG}	- 40 ~ + 125	°C	

POWER DISSIPATION CURVE

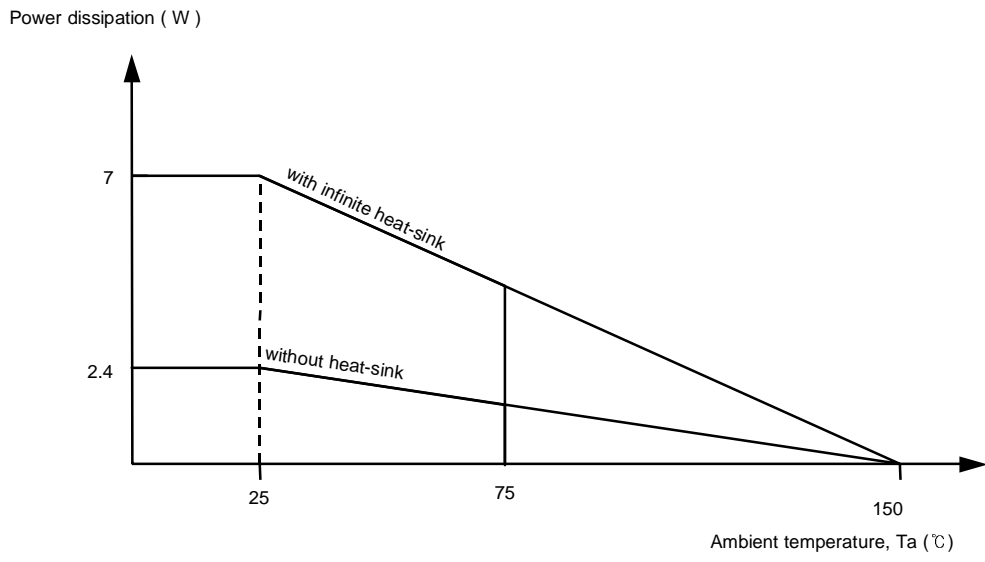

ELECTRICAL CHARACTERISTICS(Ta=25 °C, V_{CC1}=5V, V_{CC2}=16V, R_S=0.5Ω, unless otherwise specified)

Characteristics	Symbol	Pin No.	Test Conditions	Min	Typ	Max	Unit
Quiescent Input Current	I _{CC1}	17	V _{F/R} =0V or 5V	5	8.5	12	mA
Hall AMP Input Voltage Range	V _{INS}	1 ~ 6	mVo-p	100	-	-	mV
Power TR Saturation Voltage (Outflow Current)	V _{SAT1}	16 – 13,14,15	V _{CC2} =13V, I _{out} =0.8A/Phase	-	1.8	2.0	V
Power TR Saturation Voltage (Inflow Current)	V _{SAT2}	11- 13,14,15	V _{CC2} =13V, I _{out} =0.8A/Phase	-	1.8	2.0	V
I _{LIM} Input Voltage Range	V _{LIM}	19		0	-	V _{CC1}	V
I _{LIM} Input Current	I ₁₉	19	V _{CTL} =3.5V, V _{LIM} =3V	-	350	2,000	nA
I _{LIM} Current Limit Level	GML	19 – 13,14,15	V _{CTL} =3.5V, V _{LIM} =Adjustable	0.61	0.67	0.73	A/V
I _{LIM} Quiescent Output Current	I _{O1}	19	V _{LIM} =0V	-	1.5	5.0	mA
I _{LIM} Limit Offset Voltage	V _{O1}	19	V _{REF} =2.5V	1.17	1.25	1.33	V
V _{CTL} Input Voltage Range	V _{CTL}	20		0	-	V _{CC1}	V
V _{CTL} Input Current	I ₂₀	20	V _{CTL} =3V, V _{LIM} =5V	-	350	2,000	nA
V _{CTL} Control Gain	GM	20 – 13,14,15	V _{LIM} =5V, V _{CTL} =Adjustable	0.9	1.0	1.1	A/V
V _{CTL} Quiescent Output Current	I _{O2}	20	V _{CTL} =0V	-	1.5	5.0	mA
V _{CTL} Input off-Set Voltage	V _{O2}	20	V _{CTL} = Adjustable	-50	0	50	mV
Foward Rotation Mode	V _F	32		1.0	1.3	1.6	V
Reverse Rotation Mode	V _R	32		0	-	0.8	V
V _{REF} Input Voltage Range	V _{REF}	21		2.0	-	V _{CC1} - 2.0	V
FG _{AMP} Internal Reference Voltage	V ₂₈	28		2.2	2.5	2.8	V V
FG _{AMP} Input Voltage Range	FG _{IN}	27,28	Pin 28=10kHz,60mVp-p,	1		4	
FG _{AMP1} Gain	FG _{AV1}	28-29	Sinusoidal Waveforms Pin 27=10kHz,60mVp-p,	28	31	34	Times
FG _{AMP2} Gain	FG _{AV2}	27-30	Sinusoidal Waveforms Pin 22=2.5V	28	31	34	Times

APPLICATION INFORMATION

1. HALL INPUT

The input signal of the Hall Sensor requires more amplitude than 100mVo-p. and the operating voltage level of the Hall Sensor is from 1.2V~V_{CC1}-0.8V.

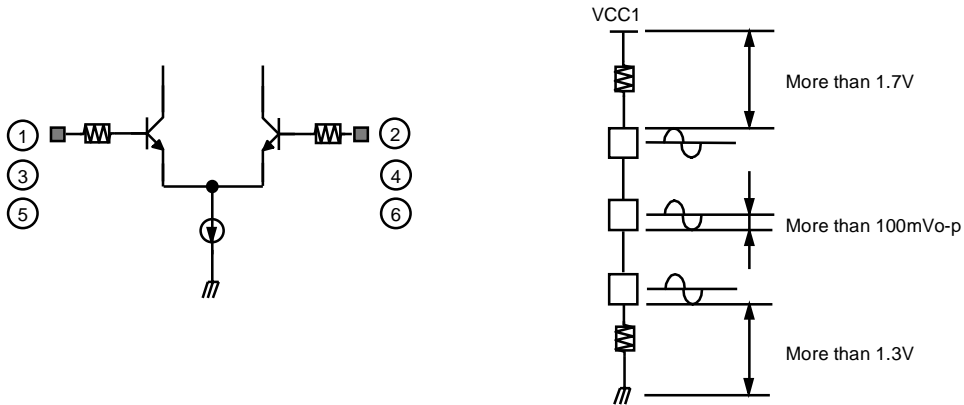

2. OUTPUT CURRENT DETECTION

Pin 11 is usually connected with Rs(approx. 0.5Ω), and the motor current is converted to a voltage by the Rs and provided to a feedback amplifier. Pin 12 is connected to the circuit with the ground side or Rs.

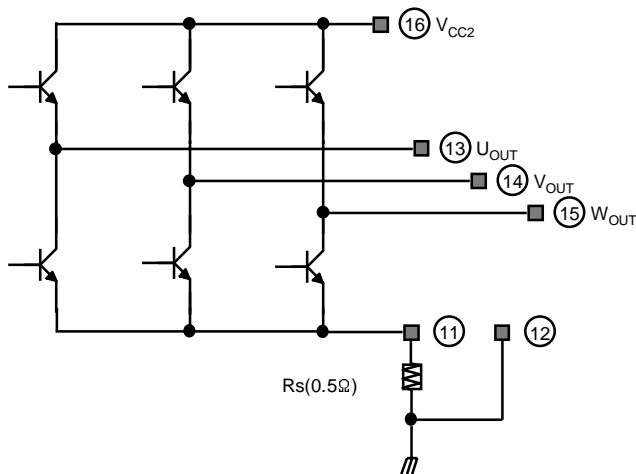

3. MOTOR SPEED CONTROL(INPUT CURRENT LIMITATION)

The maximum output current is limited by Pin 19 voltage as follows. So a motor speed is controlled by the output current. In case of no-use, it is to be short-circuit with V_{CC1} .

$$GML = \Delta I_o / \Delta V_{LIM} = (I_{o2} - I_{o1}) / (V_{LIM2} - V_{LIM1}), \text{ where } V_{LIM1} = 1.45V \Rightarrow \text{Output current} = I_{o1}$$

$$V_{LIM2} = 1.55V \Rightarrow \text{Output current} = I_{o2}$$

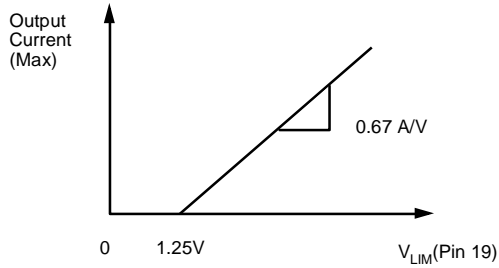
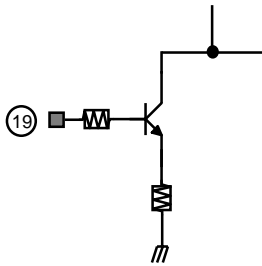

4. MOTOR SPEED CONTROL(INPUT VOLTAGE CONTROL)

The control of motor speed is possible on the conditions of $V_{CTL}(\text{Pin } 20) \geq V_{REF}$. The control gain is approx. 1.0 A/V as follows.

$$GM = \Delta I_o / \Delta V_{CTL} = (I_{o2} - I_{o1}) / (V_{CTL2} - V_{CTL1}), \text{ where } V_{REF} = 2.5V, V_{CTL1} = 2.6V \Rightarrow \text{Output Current} = I_{o1}$$

$$V_{REF} = 2.5V, V_{CTL2} = 2.7V \Rightarrow \text{Output Current} = I_{o2}$$

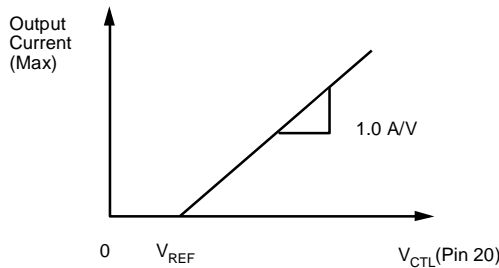
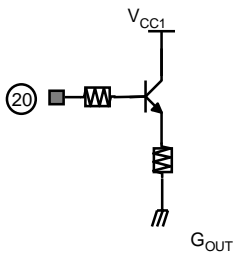

5. VOLTAGE CONTROL REFERENCE

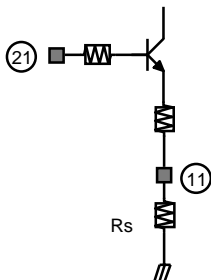

The input voltage range is $2V \leq V_{REF} \leq (V_{CC1} - 2V)$.

6. TORQUE RIPPLE CONTROL

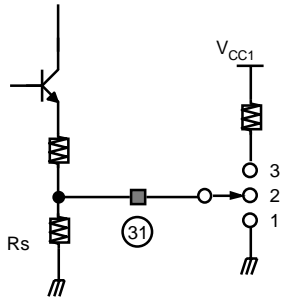

The motor torque ripple is controlled by Pin 31 voltage as follows.

- 1 : GND
- 2 : Normal Mode
- 3 : Control Mode

7. FORWARD & REVERSE ROTATION CONTROL

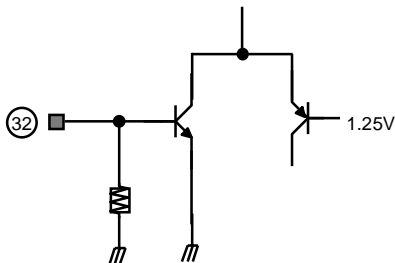

Forward mode : Pin 32 \geq 1.8V

Reverse mode : Pin 32 \leq 0.8V

8. FG AMP

These amplifiers are the inversion type. One amplifier is built in both the reference voltage (approx. 2.5V) and the gain setting resistors. The voltage gain is approx. 31 times.

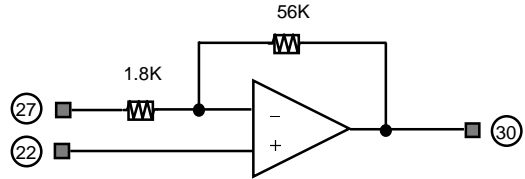
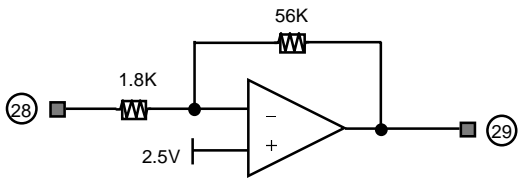

9. PHASE STABILIZATION

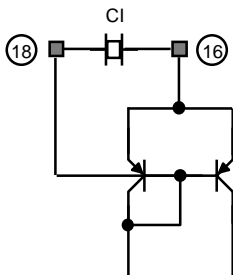

Be inserted a capacitor between Pin 16 and Pin 18. This capacitor, approx. $0.1 \mu F$ is for the phase stabilization of the circuit.

TEST CIRCUIT

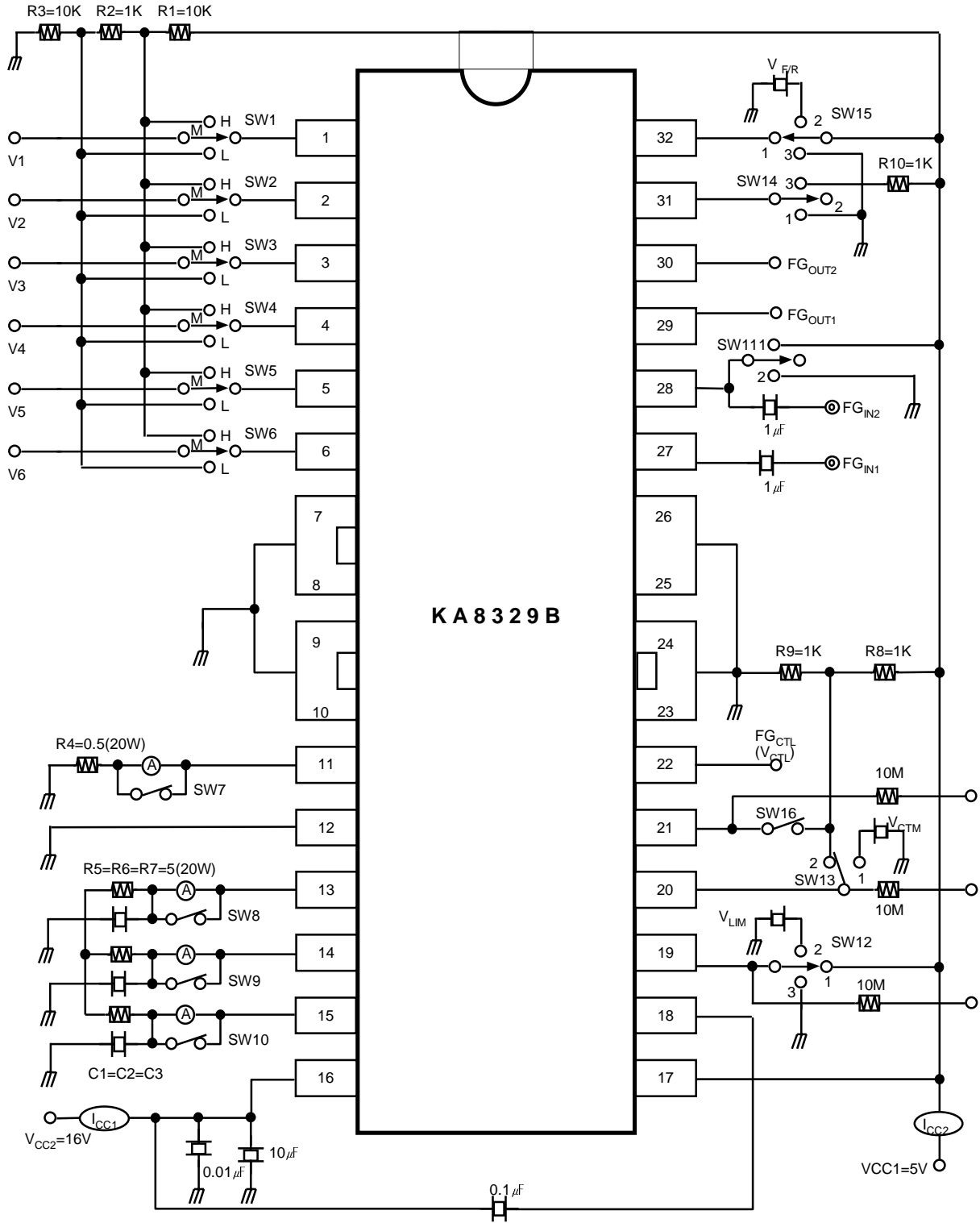

TIMMING CHART

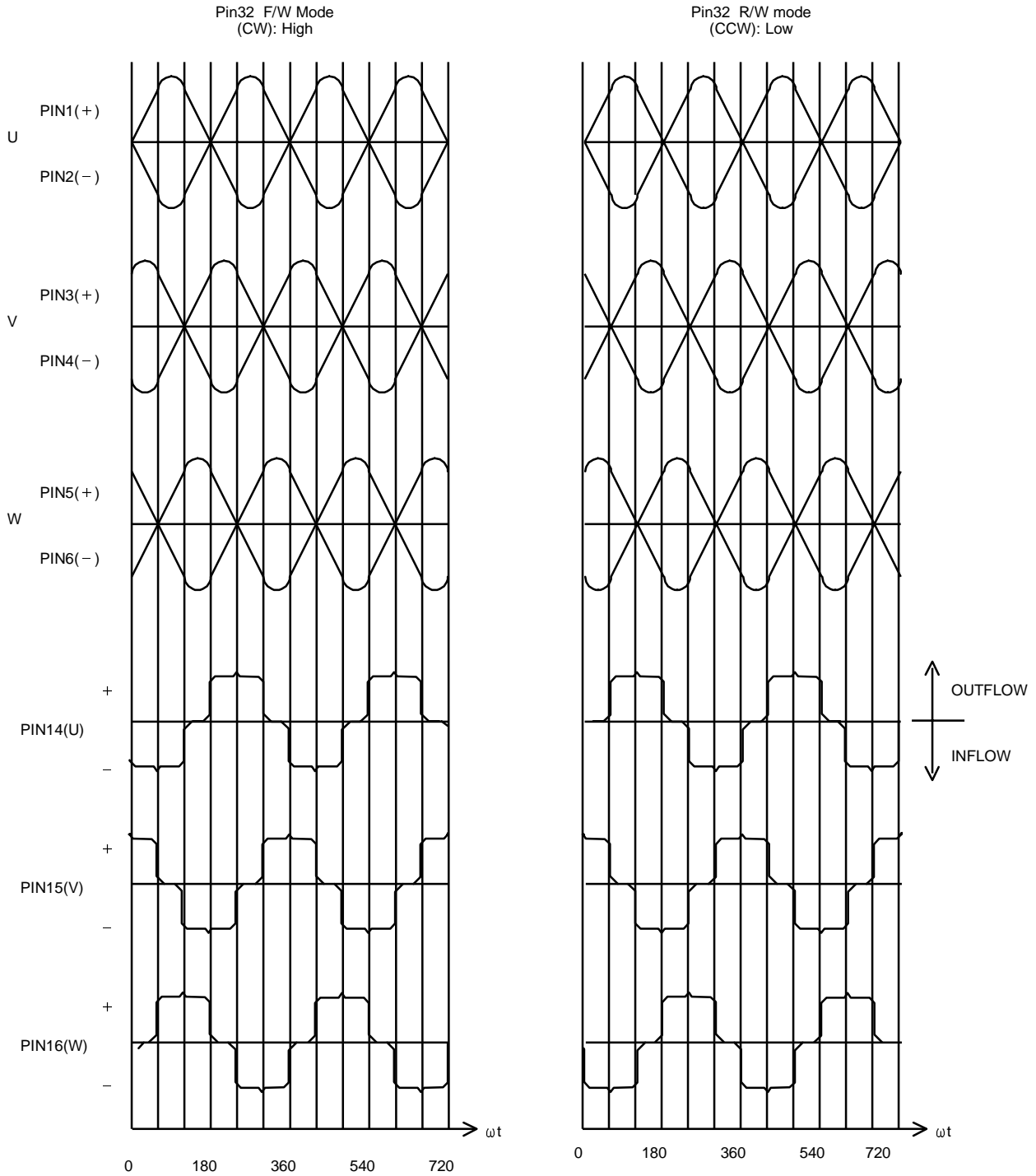

APPLICATION CIRCUIT

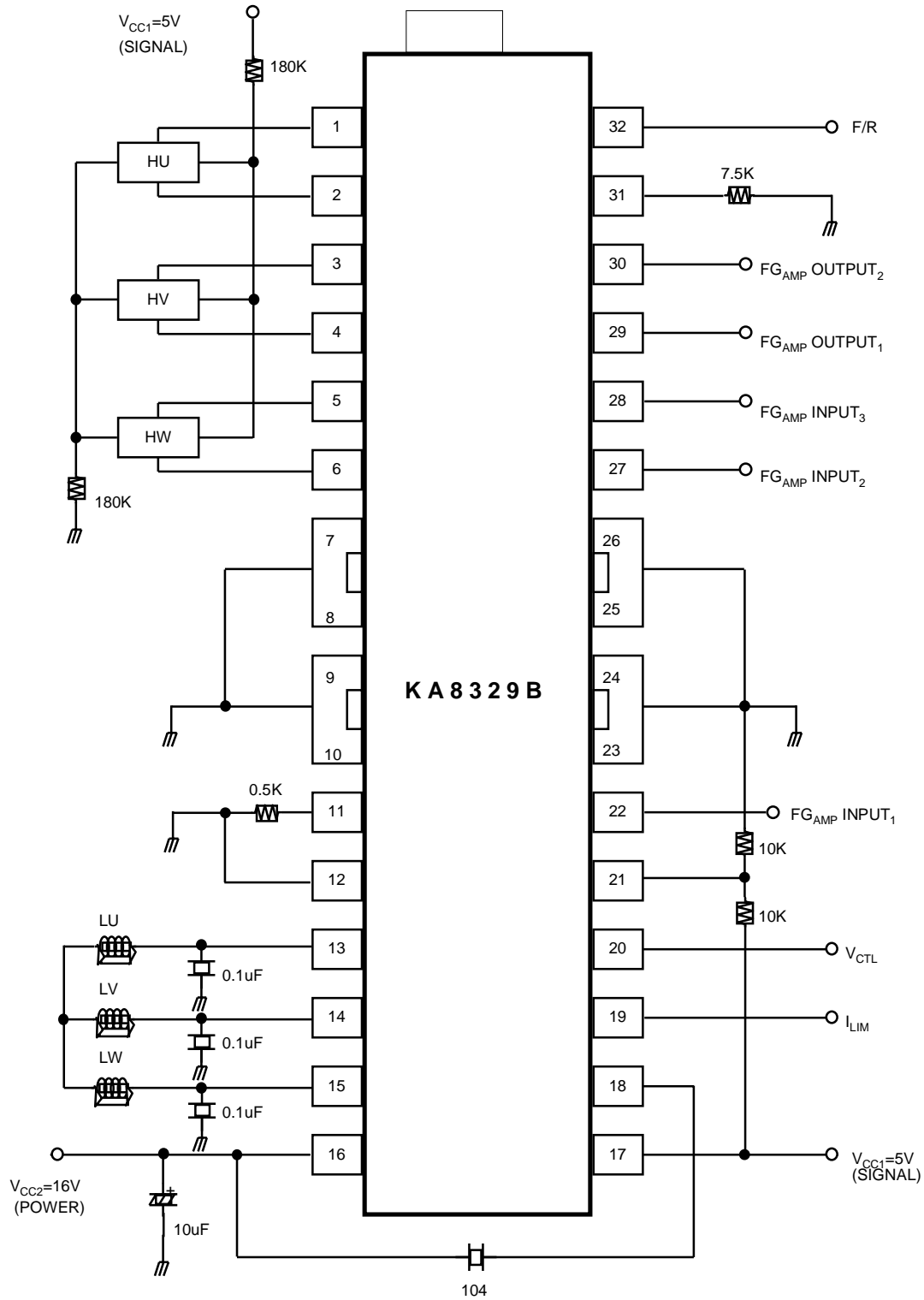

PACKAGE DIMENSIONS (Unit : mm)

32-SDIPH-400

